

T-Roof YAP 2200

Roofing underlay

Fastening is done mechanically at the overlap in the lower layer alternatively open and visible through both layers with anti-corrosive roofing nails dim. 25 x 2.5 mm. Overlaps are made with adhesive edge to adhesive edge, and for any cross joints or the like, with approved roofing felt adhesive. Consider the weather when mounting adhesive edges. Heat the rolls in a warm room if the temperature is below +10°C.

1.A Mounting

Lay underlay across the direction of the roof slope. Roll from right to left so that the side inside the roll is rolled out face up. It is easiest to lay the underlay from the bottom, with overlapping at the top. The surface should be dry, even and stable, to avoid any sagging or movement. The surface layer determines the nature and the minimum slope of the underlay. Minimum underlying clapboard wood panel thickness, for battened roofs, at least 20 mm, and for non-battened roofs, at least 23 mm.

Note: The space under the wooden substructure or over the insulation must be ventilated as per established practice.

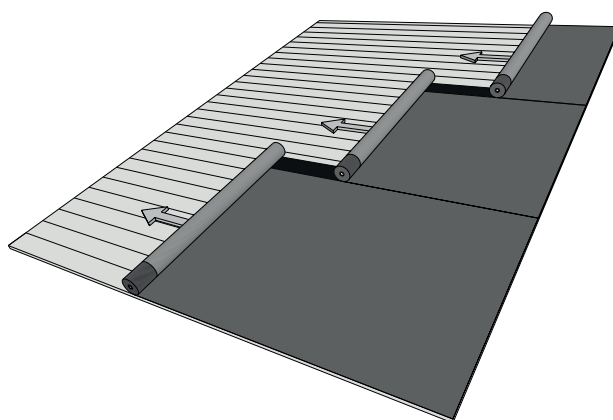

1.B Gables

The start and finish toward the gables is best done against a triangular strip that angles upward from the underlay. The roofing underlay is wound around the strip and visibly affixed on the outside.

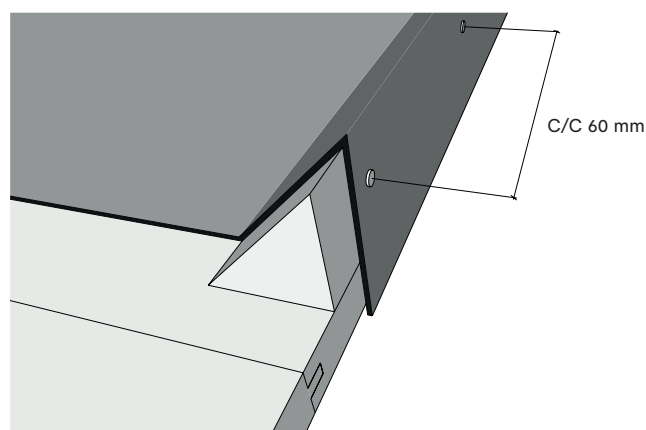

2. Joints

Mechanically fasten the roofing underlay using roofing nails, min 25 x 2.5 mm (as shown in Fig 2.B), openly and visibly (through both layers of the overlap) in the longitudinal and transverse joints. Temporarily attach the layer at the top (about 1 m between attachments) and adjust at the bottom. With a straight overlapping border, peel off the protective film from the overlapping edge and carefully apply pressure. Create the overlap with adhesive edge to adhesive edge, corresponding to the recommended overlap. Alternatively, use mechanical fastening concealed in the upper adhesive edge of the layer.

NB If concealed fastening is used, carefully check the strength of the seam afterwards. Take into account severe weather conditions, and ensure temporary fixing of the overlap or protective cover, if appropriate, until the permanent surface is installed. Alternatively, use counter-battens if possible. In the case of transverse seams, the lower edge of the overlapping layer must overlap by at least 150 mm and then be cut at an angle such that the overlap at the upper edge is equal to that at the lower edge (150 mm) + 300 mm. Attach the lower layer to the edge using mechanical fastening, c-dimension 60 mm (as shown in Fig. 2.A). Make sure to glue down transverse seams with three strings of roofing adhesive equivalent to Sealing Compound K-36. In the case of open and visible attachment, use roofing nails to nail down the overlap.

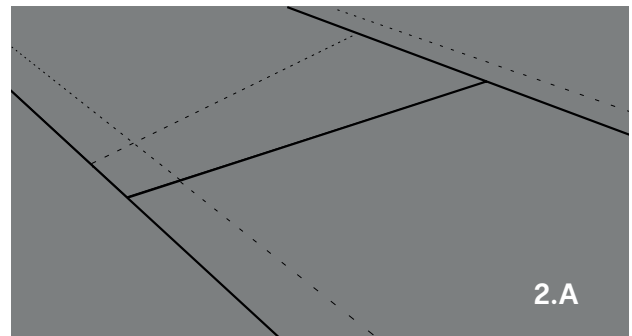
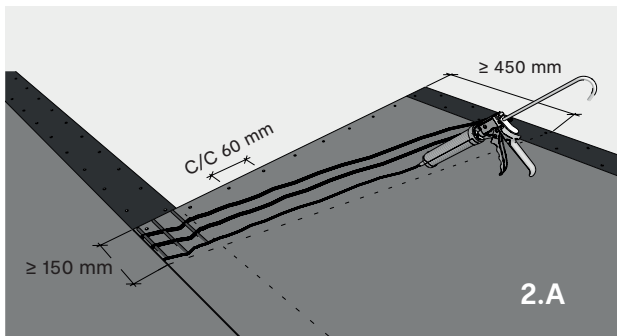

2.B

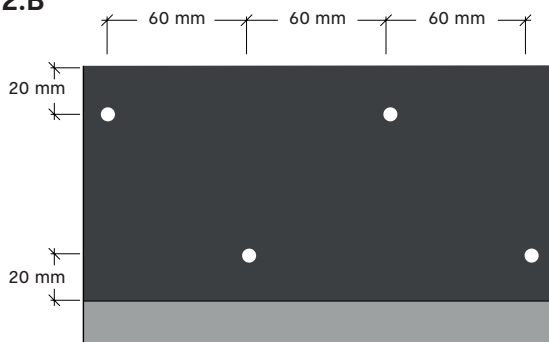

3. Eave

At the eave of the roof, attach the first layer at the lower edge to the recommended eaves lining sheet with the adhesive edge (don't forget to remove the protective film) and 3 strings of roofing felt adhesive corresponding to Sealing Compound K-36 (as in fig. 3). The termination is made a little higher (about 20 mm) so it is hidden by the protective surface in the working environment. Glue on a clean lining sheet. The eaves lining sheet should be mounted on a strip of underlay above the wooden substructure (e.g. T-Roof Multi Strip).

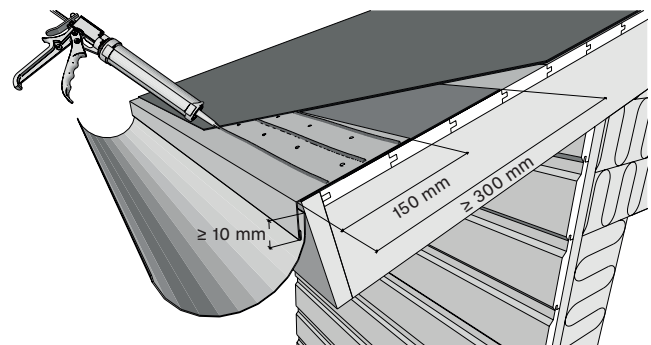

4.A Ridge ventilated

A ventilated ridge is arranged with termination at the end of the wooden substructure towards the ventilated opening. Secure at the top with roofing nails. Ensure that the ridge batten is covered with a suitable strip of underlay down towards and out on top of the counter-batten so it is clamped by the top support batten.

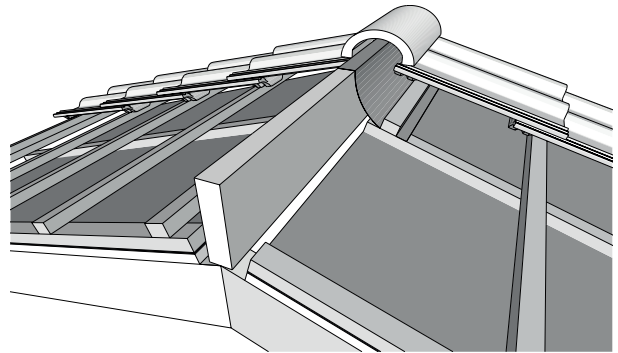

4.B Ridge sealed

In the case of a tight roof ridge, mechanically fasten the underlay against the top edge of the ridge batten and over on the other side using roofing nails, for example. The ridge batten is covered from both roof sides and also forms the underlay overlap. If no ridge batten is used, the overlap must be on each side of the roof and be at least 500 mm. Affix the lower layer with roofing nails, and glue the upper layer down with roofing adhesive equivalent to Sealing Compound K-36.

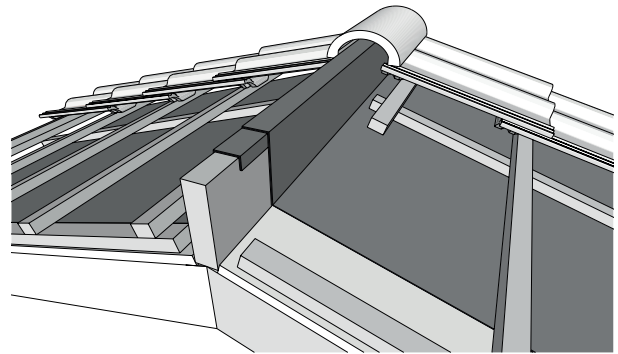

5. Roof valley

First, make sure that the valley has a stable and fixed bottom with sheet metal flashing (min 300 mm wide). The flashing must be fitted with a strip of underlay underneath. The flashing must be nailed, to mechanically hold the roof sides together. In the case of a gutter valley plate, the gutter must be fitted with a strip of underlay (as in fig. 5). The underlay in the valley gutter is attached at the ridge and at the outer edges with, e.g. roofing felt nails, c-dimension 100 mm. Then allow the connecting underlays from each roof side to overlap the valley underlay by at least 150 mm. Affix using roofing felt adhesive equivalent to Sealing Compound K-36.

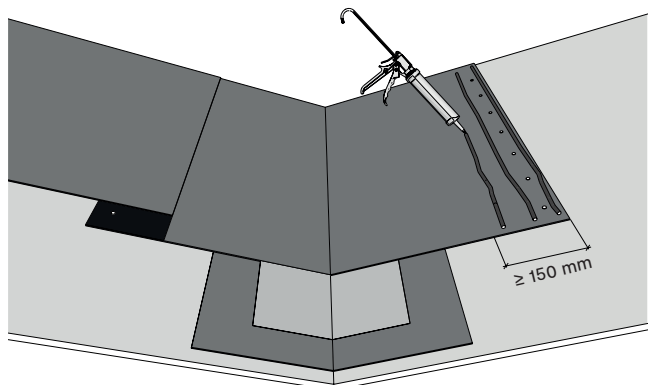

6. Pass-Through options A, B and C

- A. In the case of square penetrations (chimney, ventilation duct, etc.), the roofing underlay must be cut to size, folded up and nailed to the bottom (as in fig. 6.A). Then wrap the fold with a strip of the underlay all around with overlaps (at least 300 mm high). Fasten with nails and glue (80 mm wide or 3 strings), or nail at the bottom. Nailing is done with a c-dimension of at least 100 mm. Gluing is done with Sealing Compound K-36 adhesive or equivalent. Apply extra sealant, Sealing Compound K-36 or an equivalent sealant or resistant elastic sealing tape (Roofseal-T), to the corners. Finally, in the case of batten constructions, the penetrations are fitted with sheet metal flashing at the bottom and all the way around!
- B. For square penetrations and lower roof pitches ($\leq 12^\circ/1:5$), higher protection and mounting with adhesive collars (as in fig. 6.B) is recommended. Cut out four sides from the underlay (overlap 150 mm), cut to size and attach the bottom one first, followed by the two sides, and finish with the rearmost side towards the ridge. Glue all edges with Sealing Compound K-36 or equivalent (80 mm wide or with 3 strings).
- C. For round penetrations such as holes for ventilation pipes, etc., use a self-adhesive T-Stos Butyl collar or solid rubber collar (as in fig. 6.C). Glue the base of the collar fully to the substructure and the underlay. For solid rubber stoppers, glue with Sealing Compound K-36 or equivalent. In case of a sanded surface and use of self-adhesive collar, the surface of the underlay must be pretreated with asphalt Primer K-80. In the case of a square foot, place one of the collar corners straight up against the ridge. The collar must be sealed at the top with a clamping ring or at least 2 turns of durable sealing tape.

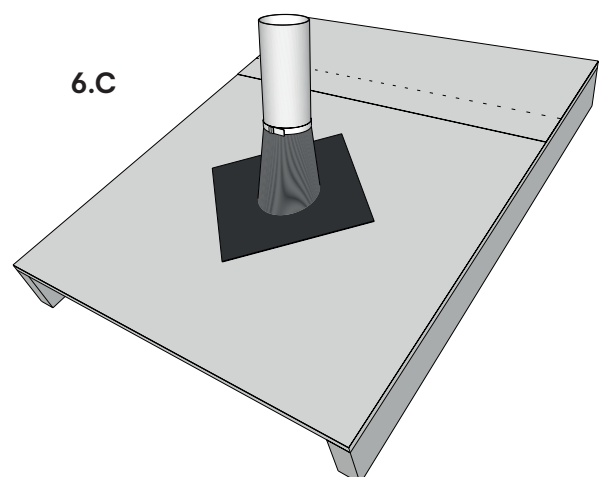
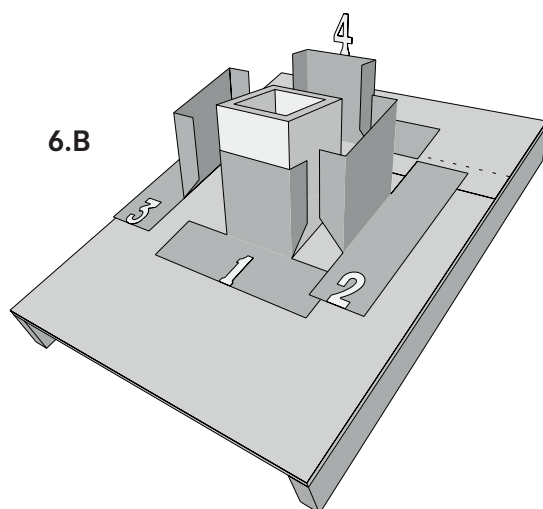
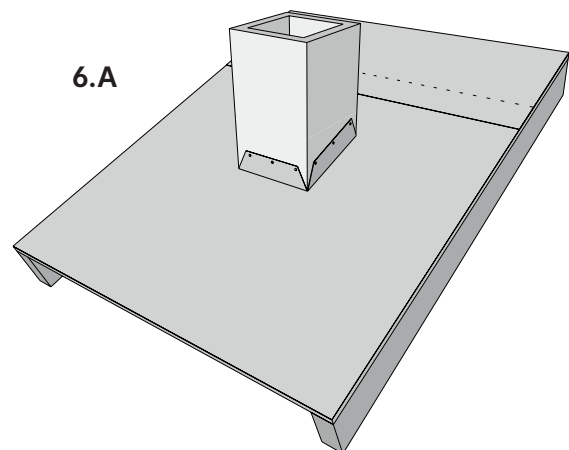
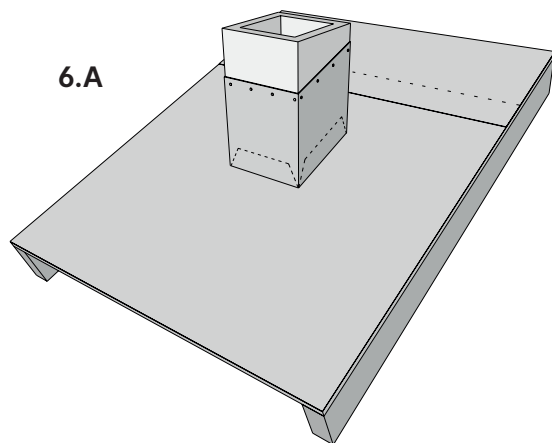

7. Vertical intersection (wall)

At the intersection where the top edge of the ceiling meets the wall (as shown in fig. 7), a minimum of 300 mm must be pulled up on the wall. The underlay is pulled up under the facade and attached to the windbarrier layer with roofing felt nails c-dimension 100 mm at 30 mm from the edge. In the case of a battened outer roof, the intersection is fitted with a metal fitting above the underlay.

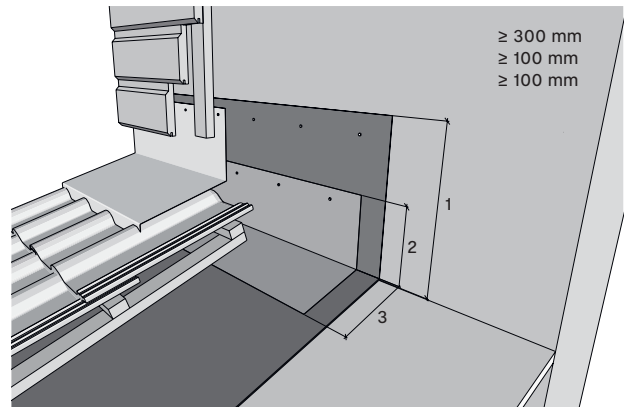

Important

- The permanent surface determines the minimum roof pitch for the underlayment, but is always at least 1,5° (~1:40) exposed but not battened roof. If battened and exposed without outer roof covering, at least 14° (1:4)! If battens are needed with a pitch of less than 14° (1:4), this must be done in connection with mounting of the external roof.
- In the case of open and visible attachment, be aware of roof pitches of <14° (<1:4) where the roofing underlay may be exposed to precipitation and/or where the outer roof covering is not mounted in direct connection. Coat open and visible nails with Sealing Compound K-36 or an equivalent bitumen sealant.
- For external roofing of flat roof tiles, the supplier's guidelines for underlayment must be followed! For non-rabbeted roof tiles or in windy locations (coastal), it is recommended to choose a safer underlay, such as T-Roof Epic.
- The underlay should not be combined with top layers that are hot-air mounted (welded).
- In the case of concealed fastening, carefully check the strength of the seam afterwards. Take into account severe weather conditions, and ensure temporary fixing of the overlap or protective cover, if needed, until the permanent surface is installed!
- The adhesive edge provides aggressive adhesion under normal conditions! In cooler weather (<+10°C), there may sometimes be a need to improve adhesion. Use a hot air gun and heat the adhesive surfaces with care. Press the seam together carefully! In cool weather, rolls should be stored for at least 1 day in hot storage.
- Treat the surface gently and immediately repair any damage with Sealing Compound K-36 or equivalent bitumen sealant. In case of major damage, use and mount/glue a piece of the roof underlayment.
- Mechanical fastening shall be hot-dip galvanised roofing nails min. 25 x 2.5 mm.
- Always cover the surface layer (tiles, sheet metal, etc.) as soon as possible, to avoid the harmful effects of sunlight and bad weather conditions. During construction, the underlay can be exposed to sunlight for up to a maximum of three months. At the use stage, the underlay must be protected by the external roof covering.
- Rolls should be stored upright on a flat, dry surface and protected from sun and precipitation.
- T-Roof YAP 2200 is damp-proof, and when installed on a wooden substructure, the space underneath should be ventilated according to professional practice.